



International Conference on Robotics and Smart Materials (RoSMa2018)

Development of Rehabilitative Multimodal Interactive Pet Robot for Elderly Residents

Jaichandar Kulandaidasan Sheba^{a*}, Le Tan Phuc^b, Adnan Ahmed Salman^a, Sampath Kumar^a, Mohan Rajesh Elara^c, Edgar Martínez-García^d

^a*School of Electrical and Electronics Engineering, Singapore Polytechnic, Singapore*

^b*Nanyang Technological University, Singapore*

^c*Engineering Product Development, Singapore University of Technology and Design*

^d*Institute of Engineering and Technology, Universidad Autónoma de Ciudad Juárez*

Abstract

The ongoing development in robotics has enabled socially interactive robots (SIR) to contribute towards elderly care. Various studies on using therapeutic robots in health care for elderly people conducted for the last decade have indicated the effectiveness of these methods. To capture and retain attention among elderly, there is a need to develop multimodal robots convincingly mimicking customizable social interaction between a human and robot. We developed our own therapeutic robot dog platform, named SNOWY, which provides a customizable level of interaction with patients, advanced motion and the ability to integrate with other interactive devices to provide a complete kit based on individual needs.

© 2018 The Authors. Published by Elsevier Ltd.

This is an open access article under the CC BY-NC-ND license (<https://creativecommons.org/licenses/by-nc-nd/4.0/>)

Peer-review under responsibility of the scientific committee of the International Conference on Robotics and Smart Materials.

Keywords: Therapeutic Pet Robots, Bio-inspired robots, Robot-assisted therapy, Dementia, Interactive Robots.

1. Introduction

Various studies on using therapeutic robots in health care for elderly people conducted for the last decade have indicated the effectiveness of this method to improve moods and depression, encourage communication, decrease stress level and physiological improvement [1]–[11]. Vast research work has been carried to design efficient quadruped robots [12]–[17]. Studies suggest that pet robots can positively affect the wellbeing of elderly in nursing home. Commonly used robots in those studies including: Seal-like therapeutic robot PARO, entertainment robot dog AIBO, cat-like robot Necoro, etc. in which they have their own advantages and drawbacks. For instant, PARO

* Corresponding author. Tel.: +65-94886303; fax: +65-67721974.

E-mail address: jai@sp.edu.sg

and Necoro have a high level of implemented behaviors [2] as well as sensing and recognition but limited in motion and a great concern on cleaning and hygienic issues after a period of usage [11]. Similarly, AIBO and other pet-like robots have some degrees of advanced motion like walking, dancing, rolling but lack of stability in engaging between users and robot compared with living animal [2] and the ability to be upgradable. Moreover, these therapeutic robots operate independently as a black-box without collaborating with other supportive devices and games which restrict the potential to develop more activities for patients. Thus, we developed our own therapeutic robot dog platform, named SNOWY, which provides customizable level of interaction with patients, advanced motion and the ability to integrate with other interactive devices to provide a complete kit based on individual needs.

Nomenclature

$P(x, y)$ – coordination of point P in x, y direction.
 P_i – coordination of point i in the walking trajectory
 l – link length, [mm]
 θ_i – joint i angle, formed by link i and link $i - 1$, [rad]
 α – end-point angle, respect to platform horizon, [rad]

β – end-point angle, respect to link 1, [rad]
 d – one-third of the support trajectory length, [mm]
 n – walking cycle
 s_{su} – moving speed in support phase, [rad/s]
 s_{sw} – moving speed in swing phase, [rad/s]

2. The robotic dog platform for elderly companionship – SNOWY

The dog robot, SNOWY is shown in Fig. 1. Its appearance is designed using a small dog as a model, and its surface covered with white faux fur. The face resembles a cute puppy and the fur coat gives a soft natural feel when cuddling. Snowy is equipped with sensors to receive inputs from peripheral devices and respond by actions like walking, nodding head, squatting and play sound or music based on user inputs.

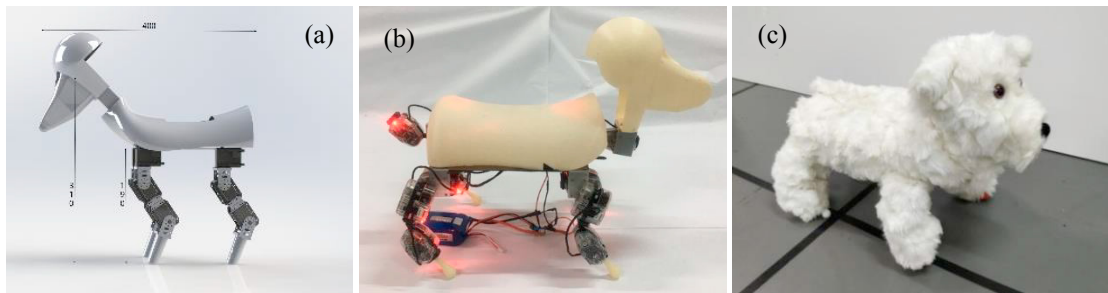

Fig. 1. Mechanical hardware design of the robot platform.-CAD design (a) bare mechanical frame without cover (b) and with soft fur covers (c) of the platform. The cover can be easily removable for washing and cleaning.

2.1. Hardware design

The development of SNOWY has gone through number of iteration with changes in the mechanical design, control system, walking gait and interactive peripheral interfaces to achieve the final design as shown in Fig. 1. SNOWY consists of 4 legs and a flexible neck. Each leg is driven by 3 smart servo motors while the head of the robot dog is attached with the body by a 2-degree of freedom servo motor system which acts as a neck. In total, there are 14 smart servo motors shared the same communication interface controlled by the main controller board. This makes SNOWY very flexible and configurable in terms of motion control. The platform's main chassis is formed by a 1.5mm A5-size Aluminum alloy plate to provide strong support for other parts yet reduce the weight of the entire platform. Other components such as body frame, head, links, brackets and hooves were designed and 3D printed with PLA material to further lighten the platform weight and make it easily replicable and replaceable. The minimal design shape for the chassis ensures appropriate modularity and allows a symmetric and adequately

large workspace when different sensor fusion is to be integrated. Variable footpads are installed to run test trials and operations on different terrains. Table 1 presents the general characteristics of the platform in terms of mechanical hardware, electronic controller and actuators aspect. A custom-made controller based on ATMEGA2560 microcontroller was designed to perform centralized computation and integrate different peripherals including touch, sound, vision and motor control connectivity as seen in Fig. 2.

Table 1. Characteristics of the mechanical hardware, electronic controller and actuators of the robot platform

Characteristic	Value
Smart servo motor	Wck-1111T
Controller	Custom-made ATMEGA2560 controller board
Sensing system	Capacitive proximity touch
Communication	XBee 802.15.4 standard
Power supply	7.2V 1.5Ah LiPo battery
Total weight (Mrobot)	1200g
Total DOF	14

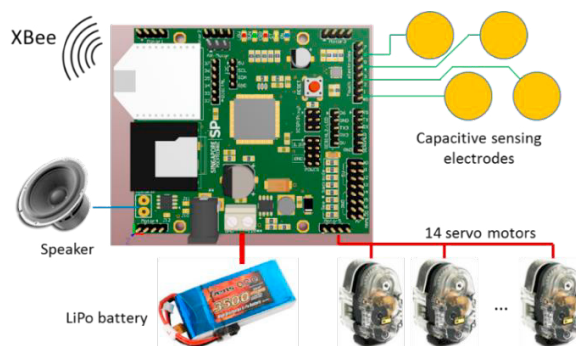

Fig. 2. Control system architecture of SNOWY

As mentioned in the previous part, all 14 smart servo motors share the same serial connection port which provides a neat solution for wiring of multiples motors. Each servo motor has a unique identification (ID) address and different command sets to separately control the position, speed and acceleration accurately. The controller board also has the capability of proximity sensing up to 12 individual capacitive electrodes. However, for a spatial consideration, 8 electrodes are distributed at different locations on the SNOWY's body for this current platform. These electrodes are being used as the biomimetic stimulus of the robot to provide a set of reactive motions and sounds feedback through an in-built speaker accordingly. Wireless communication with other supportive peripherals, shown in Fig. 2, **Error! Reference source not found.** through ZigBee mess network is another feature of this platform compared to other therapeutic robot platforms. Furthermore, the entire platform is powered by a 7.4V, 1500mAh LiPo battery which provides continuous operation for more than one hour after fully charged.

2.2. Motion control

To make SNOWY a lively and interactive robot platform, different sets of motion is implemented which can be classified into two groups: basic motions and advanced motions.

2.2.1. Basic motions

Basic motion of the platform includes sitting, standing, head nodding and head shaking. For these simple motions, a pre-defined coordination and movement sequences of each joint are programmed into several subroutines that can be called when needed.

2.2.2. Advanced motions

Advanced motion including walking, dancing and swinging requires a higher level of computation and cooperation among all 14 motors to provide smooth and stable movement of the platform. To achieve this, inverse kinematics calculation has been implemented into the advance motion algorithm to offer such solution. Since the robot platform has 4 legs, let us define the names for four legs in respect to their relative positions on the body platform, which will be used in later part for identifying and calculation of the walking synchronization. Fig. 3 presents the definition of four legs on the platform, which are Left Fore (LF); Right Fore (RF); Left Hind (LH); and Right Hind (RH).

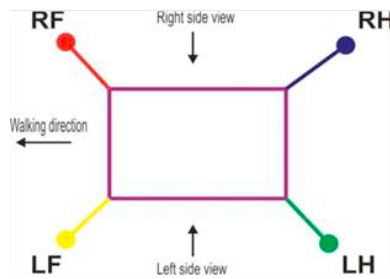

Fig. 3. Definition of four legs of the robot with respect to their relative position on the platform, which are called: Left Fore (LF); Right Fore (RF); Left Hind (LH); and Right Hind (RH).

a. Inverse kinematics solution for robot leg model

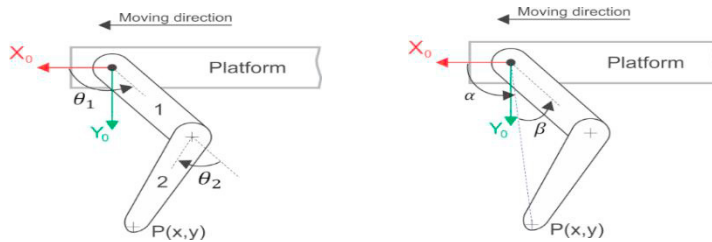

Fig. 4. Frame allocation of the simplified model of the leg with notations for different joint angles

As can be seen from Fig. 4 (left), the end position $P(x, y)$ of the leg is unique for any set of joint angles θ_1 and θ_2 . This is also known as the forward kinematics problem. However, the known information now is the position where the leg should be located, multiple joint angles need to be calculated to control the corresponding motors to move the leg to that desired position by solving the inverse kinematics problem. Since the leg only comprises two links, we simply implemented the geometric approach with restrictions on joint limits to reduce the computation to the controller of the robot. By cosine theorem, we have:

$$P_x^2 + P_y^2 = l_1^2 + l_2^2 - c \cos(\pi - \theta_2) \tag{1}$$

where P_x and P_y are coordination of the end point P ; $l_1 = 45 \text{ mm}$ and $l_2 = 85 \text{ mm}$ are the lengths of link 1 and link 2 respectively and θ_2 is the rotating angle of joint 2. From (1), the rotating angle θ_2 can be calculated by

solving the equation:

$$\theta_2 = \cos^{-1} \left(\frac{P_x^2 + P_y^2 - l_1^2 - l_2^2}{2l_1l_2} \right) \tag{2}$$

Noted that the condition to have this equation solvable is that the end-point P must be inside the reachable workspace of the two links, which can be represented as:

$$\sqrt{P_x^2 + P_y^2} \leq l_1 + l_2 \tag{3}$$

The solution for θ_2 will have two configurations, $\theta_2 \in (-\pi, 0)$ and $\theta_2 \in (0, \pi)$. Since the mechanical hardware was designed to allow the motor of joint 2 to move in range of $(-\pi, 0)$, this solution is selected. Subsequently, the θ_1 of joint 1 is calculated based on the solution of θ_2 . Let us define the angle α and β as seen from Fig. 4 (right). We have:

$$\alpha = \text{atan2}(P_x, P_y) \tag{4}$$

and from cosine theorem,

$$\beta = \cos^{-1} \left(\frac{P_x^2 + P_y^2 - l_1^2 - l_2^2}{2l_1\sqrt{P_x^2 + P_y^2}} \right) \tag{5}$$

where $\beta \in (0, \pi)$. Based on (4), (5) and the condition of $\theta_2 \in (-\pi, 0)$, the joint 1 angle θ_1 can be simply calculated by

$$\theta_1 = \alpha + \beta \tag{6}$$

From (2) and (6), the inverse kinematics solution for every desired position $P(x, y)$ is unique as long as $P(x, y)$ satisfies the condition stated in (3).

b. Walking trajectory for standard walking motion

Once the angles of two joints of each leg are uniquely determined, we now introduce the simple walking trajectory which drives the motion of the leg in the way that the dog could move forward stably. Fig. 5 illustrates such trajectory (dotted, pink color) which is basically a rectangular shape trajectory.

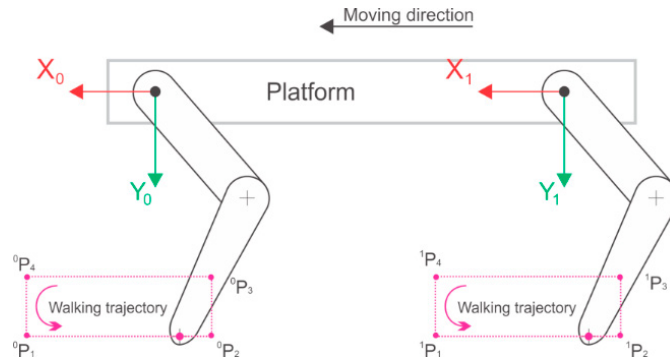

Fig. 5. Rectangular shape trajectory was chosen as walking trajectory for its simplicity.

The walking trajectories are determined by four anchor points, iP_1 , iP_2 , iP_3 , and iP_4 , connected by 4 lines where $i = 0, 1, 2, 3$ is the index of the leg. Each line of the trajectories is then divided into many small segments, in which for this case, each segment is 1mm long. By applying linearization method, each segment of the lines is considered as a point with different coordination (x, y) and subsequently fed into inverse kinematics equations to solve for two joints' angle. Thus, a data set of joints' angles is created corresponding to the chosen trajectory. Through trial and error method, we determined the dimensions of the walking trajectories as 96mm in length and 20mm in height that provides the best stable walking motion corresponding to the current hardware development of the dog. The

detailed positions of 4 anchor points ${}^iP_1, {}^iP_2, {}^iP_3,$ and iP_4 in respect to i frame are as following: ${}^iP_1 = (75, 125); {}^iP_2 = (-21, 125); {}^iP_3 = (-21, 105);$ and ${}^iP_4 = (75, 105).$

c. Walking phase synchronization of four legs

Based on the work that has been done in [11]–[14] about synchronization of walking phase for reconfigurable Klann linkage, we implemented the similar method to provide smooth walking gait for our quadrupled robot. The difference now is lying on the shape of the trajectory, which is marginally simpler in this project. As the platform has three legs in support state and one in swing state at all time, the support state is divided into three equal parts with two other states in between, say P_{11} and P_{12} , which are calculated as follow:

$$d = \frac{|P_{1x} - P_{2x}|}{3} \tag{7}$$

$$P_{12x} = P_{2x} + d \tag{8}$$

$$P_{11x} = P_{2x} + 2d \tag{9}$$

Fig. 6 illustrates all the phases of walking motion that each leg must follow to assure a stable walking motion. There are two phases: swing phase (green-dash lines) and support phase (red line) in which leg touch the ground to carry the weight of the robot in support phase and swing over the ground for the next walking cycle in swing phase. At any specific time, three legs will be in support phase to keep the robot walk or stand steadily.

Table 2. Walking phase synchronization for 4 legs

Leg	Phase 1 (n)	Phase 2 (n)	Phase 3 (n)	Phase 4 (n)	Phase 1 (n+1)
Left Fore	P_1	P_{11}	P_{12}	P_2	$P_3 \rightarrow P_4 \rightarrow P_1$
Right Hind	P_{11}	P_{12}	P_2	$P_3 \rightarrow P_4 \rightarrow P_1$	P_{11}
Right Fore	P_{12}	P_2	$P_3 \rightarrow P_4 \rightarrow P_1$	P_{11}	P_{12}
Left Hind	P_2	$P_3 \rightarrow P_4 \rightarrow P_1$	P_{11}	P_{12}	P_2

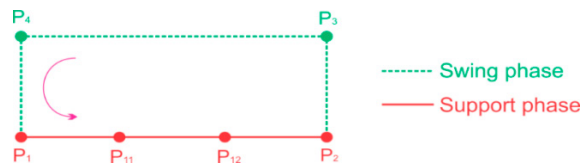

Fig. 6. The switching positions between different phases on the walking trajectory. The green part and red part of the trajectory represent leg in swing and support phase respectively.

The walking synchronization of four legs is described in Table 2 where n represents the walking cycle. It can be noticed that at some specific phase, each of four legs will perform a transition from support phase to swing phase and back to support phase, which is denoted by the sequence in the table. In the transition (swing) phase, the total amount of distance the leg in this phase must move is much larger than other legs in support phase. In other words, the speed of the leg in swing phase must be much faster than other legs to finish its motion at the same time with other legs. Specifically, the speed of legs in each phase can be described as:

- For legs in support phase, the moving speed is defined as s_{su} , which is the distance d over time $t[s]$.

$$s_{su} = \frac{d}{t} \tag{10}$$

- For legs in swing phase, the moving speed is calculated as

$$s_{sw} = s_{su} * \frac{\|P_2P_3\| + \|P_3P_4\| + \|P_4P_1\|}{d} \tag{11}$$

3. The interactive dumbbell

The dumbbell as shown in Fig. 7 (a) is essentially a custom-design Inertial Measurement Unit (IMU) chip which relies on the physical coordinates of how and where the dumbbell is moved. Depending on which action is performed to the dumbbell, corresponding commands will be sent to the dog to control its motion accordingly. The means of this peripheral is to encourage the target users to exercise with more intent in which SNOWY acts as a motivator. The IMU sensing board depicted in Fig. 7 (c), named as ActSense, also has capacitive sensing capability which is used to activate the circuit when the dumbbell is being held by the user. Implementing such a system enables the dumbbell to be very sturdy and easily accessible. The ActSense IMU sensor of the dumbbell will extract useful information from its gyroscopes and accelerometers to detect the movement of the arm, elbow and wrist to command SNOWY to walk, sideway swing and dance respectively. Hence numerous possibilities for joint activation and rehabilitation are possible for the user when using the kit.

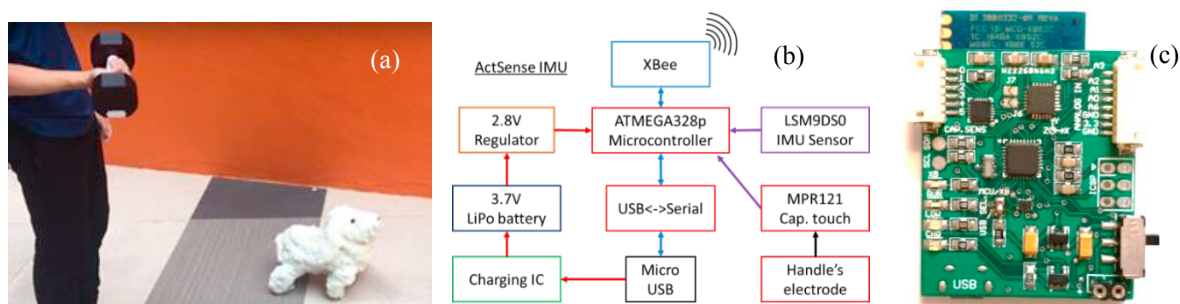

Fig. 7. Interaction between the hand motion through the dumbbell and SNOWY movements (a). Block diagram (b) and the Printed Circuit Board (PCB) (c) of the ActSense IMU board – the core of the interactive dumbbell

4. The interactive gloves

The gloves enable the elderly to control SNOWY's movements through the tips of their hands with each fingertip touching to one another allows the user to control the sitting, squatting, standing, moving and play music function. When the thumb touches the other four fingers the MCU identifies the finger and executes the specific action as programmed. An XBee transmitter with MCU inside the glove will then transmit a signal to the receiver, Snowy for appropriate action.

5. Reminiscence Therapy – Card and Block game

It works by helping the elderly remember about the past, by having a nostalgic feeling. RFID cards and readers are being used. A LCD will also be included into the game. Firstly, when the elderly turns on the game, there will be 2 options available; pictures or colors. The picture game mode allows elderly to verify the location while color game mode helps elderly differentiate assorted colors. As the game starts, each picture or color will be shown on the LCD. A set of cards will be given to the elderly as part of the game. The elderly must match either the picture or colors respectively with the set shown on the LCD. When the cards match, the next image will appear, until the end of the game. An XBee transmitter will then transmit a signal to the receiver, Snowy to respond, when the elderly gets the set correct.

6. The Music therapy game

The game has a randomly generated sequence with different LED lighting up at a different time. With each level, more LEDs will light up. Repeated patterns may occur too. The player must remember the sequence as it will be played only once. After that, the player must follow the exact sequence out by pressing touch pad at the according to the sequence of LEDs lighted up. This game has time no limit and will challenge the user to go as high level as possible. However, if the wrong button is pressed, Snowy will react to the game. The game will then return to the first level.

7. Conclusion

We have developed our own therapeutic pet robot that can interact with elderly using interactive devices. The kit can be used as an intervention and assessment tool for elderly to improve quality of life. It will reduce the workload of the caregivers as well as mitigate the possibility of physical and emotional setbacks of the elderly. The research is ongoing, but a useful method of robot therapy application has been obtained based on the [elderly and therapist feedback. The walking speed can be tuned to meet individual elderly needs](#). Therapist can use the developed device to conduct long term studies on elderly health benefits when interacting with interactive pet robot.

References

- [1] T. Shibata and K. Wada, "Robot therapy: A new approach for mental healthcare of the elderly - A mini-review," *Gerontology*, vol. 57, no. 4, pp. 378–386, 2011.
- [2] K. Wada, T. Shibata, T. Saito, K. Sakamoto, and K. Tanie, "Psychological and social effects of one year robot assisted activity on elderly people at a health service facility for the aged," *IEEE Int. Conf. Robot. Autom.*, no. April, pp. 2785–2790, 2005.
- [3] E. Libin and A. Libin, "New Diagnostic Tool for Robotic Psychology and Robototherapy Studies," *CyberPsychology Behav.*, vol. 6, no. 4, pp. 369–374, 2003.
- [4] M. Kanamori et al., "Pilot study on improvement of quality of life among elderly using a pet-type robot," *Proc. 2003 IEEE Int. Symp. Comput. Intell. Robot. Autom. Comput. Intell. Robot. Autom. New Millenn. (Cat. No.03EX694)*, vol. 1, pp. 107–112, 2003.
- [5] R. Bemelmans, G. J. Gelderblom, P. Jonker, and L. de Witte, "Socially assistive robots in elderly care: A systematic review into effects and effectiveness," *J. Am. Med. Dir. Assoc.*, vol. 13, no. 2, pp. 114–120, 2012.
- [6] H. Robinson, B. Macdonald, and E. Broadbent, "Physiological effects of a companion robot on blood pressure of older people in residential care facility: A pilot study," *Australas. J. Ageing*, vol. 34, no. 1, pp. 27–32, 2015.
- [7] N. Chernyak and H. E. Gary, "Children's Cognitive and Behavioral Reactions to an Autonomous Versus Controlled Social Robot Dog," *Early Educ. Dev.*, vol. 27, no. 8, pp. 1175–1189, 2016.
- [8] K. Thodberg et al., "Behavioral responses of nursing home residents to visits from a person with a dog, a robot seal or atoy cat," *Anthrozoos*, vol. 29, no. 1, pp. 107–121, 2016.
- [9] T. Hamada et al., "Robot therapy as for recreation for elderly people with dementia - Game recreation using a pet-type robot -," *Proc. 17th IEEE Int. Symp. Robot Hum. Interact. Commun. RO-MAN*, pp. 174–179, 2008.
- [10] Chi-Tai Cheng, Yu-Ting Yang, Jacky Baltés, Ching-Chang Wong, *An Interactive-Learning System for Pet Robots*, *IFAC Proceedings Volumes*, Volume 44, Issue 1, 2011,
- [11] T. S. Scholten, C. Vissenberg, and M. Heerink, "Hygiene and the Use of Robotic Animals in Hospitals: A Review of the Literature," *Int. J. Soc. Robot.*, vol. 8, no. 4, pp. 499–511, 2016.
- [12] J. K. Sheba, M. R. Elara, E. Martínez-García, and L. Tan-Phuc, "Trajectory Generation and Stability Analysis for Walking Robot," *Robotics*, vol. 5, no. 13, pp. 1–20, 2016.
- [13] J. K. Sheba, E. Martínez-García, M. R. Elara, and L. Tan-Phuc, "Synchronization and stability analysis of quadruped based on reconfigurable Klann mechanism," in *2014 13th International Conference on Control Automation Robotics and Vision, ICARCV 2014*, 1997, pp. 663–668.
- [14] J. K. Sheba, E. Martínez-García, M. R. Elara, and L. Tan-Phuc, "Design and evaluation of reconfigurable Klann mechanism based four legged walking robot," in *2015 10th International Conference on Information, Communications and Signal Processing, ICICS 2015*, 2016.
- [15] J. K. Sheba, M. R. Elara, E. Martínez-García, and L. Tan-Phuc, "Synthesizing reconfigurable foot traces using a Klann mechanism," *Robotica*, vol. 35, no. 1, pp. 189–205, 2017.
- [16] Rojas, Nicolás. "Distance-based formulations for the position analysis of kinematic chains." (2012).
- [17] Nansai, S., Mohan, R., and Iwase, M., 2013. "Dynamic analysis and modeling of jansen mechanism". *Procedia Engineering*, 64, pp. 1562–1571.