

PAPER • OPEN ACCESS

## Mechanical design of a low-cost ABS hand prosthesis using the finite element method

To cite this article: A Bastarrechea *et al* 2021 *J. Phys.: Conf. Ser.* **1736** 012039

View the [article online](#) for updates and enhancements.

### You may also like

- [Simulation of visual perception and learning with a retinal prosthesis](#)  
James R Golden, Cordelia Erickson-Davis, Nicolas P Cottaris *et al.*
- [Extended home use of an advanced osseointegrated prosthetic arm improves function, performance, and control efficiency](#)  
Luke E Osborn, Courtney W Moran, Matthew S Johannes *et al.*
- [GLIMPSE: Google Glass interface for sensory feedback in myoelectric hand prostheses](#)  
Marko Markovic, Hemanth Karnal, Bernhard Graimann *et al.*



The Electrochemical Society  
Advancing solid state & electrochemical science & technology

## 241st ECS Meeting

May 29 – June 2, 2022 Vancouver • BC • Canada

Extended abstract submission deadline: Dec 17, 2021

Connect. Engage. Champion. Empower. Accelerate.  
**Move science forward**



**Submit your abstract**



# Mechanical design of a low-cost ABS hand prosthesis using the finite element method

A Bastarrechea<sup>1,2</sup>, Q Estrada<sup>1</sup>, J Zubrzycki<sup>3</sup>, V Torres-Argüelles<sup>1</sup>, E Reynoso<sup>1</sup>, A Rodríguez-Mendez<sup>4</sup> and E Coutiño<sup>5</sup>

<sup>1</sup> Universidad Autónoma de Ciudad Juárez, Instituto de Ingeniería y Tecnología, Ciudad Juárez, Chihuahua, México

<sup>2</sup> Tecnológico Nacional de México campus Ciudad Juárez, Departamento de Ciencias Básicas, Ciudad Juárez, Chihuahua, México

<sup>3</sup> Lublin University of Technology, Mechanical Engineering Faculty, Nadbystrzycka 36 str., Lublin, Poland

<sup>4</sup> University of California, Berkeley, Department of Mechanical Engineering, California, United States

<sup>5</sup> Tecnológico de Estudios Superiores de Jocotitlán, Ingeniería Electromecánica, Jocotitlán, Estado de México, México

aztlan.ba@cdjuarez.tecnm.mx, quirino.estrada@uacj.mx

**Abstract.** Many hand accidents are reported around the world resulting in a necessity to perform a procedure of amputation of the hand. For this consideration, a large number of hand prostheses have been designed. However, the mechanical design of these prostheses present challenges such as kinematic functionality, strength, and cost. The present article analyses the mechanical design of a low-cost practical hand prosthesis using the finite element method with the help of Abaqus commercial software. Functional and technical requirements were considered to consider the biomechanics of the human hand. The hand prosthesis was conferred with 14-degrees-of-freedom (DOF), which gives it the capacity for grips associated with security, stability, dexterity, and sensibility. Additionally, due to practicality and low-cost manufacturing techniques, fused deposition modelling with acrylonitrile butadiene styrene (ABS) is proposed. The evaluation of the hand prosthesis was carried out by tensile, flexural, and torsional load conditions. Finally, the mechanical effectiveness of the designed prosthesis was demonstrated since maximum stresses close to 13 MPa were computed, which are less than the yield stress of ABS.

## 1. Introduction

Every year, millions of hand amputation surgeries are performed according to Plott et al. [1]. The quality of life of patients who were subjected to such a procedure, including emotional health and independence, is highly compromised. In order to help them and replace the amputated limb, several prosthetics devices have been proposed [2-7]. Prostheses are designed to return functionality to the upper limb with cosmetic appearance. However, prostheses present several problems associated with kinematic functionality, cost, adaptability, and durability [8]. For this purpose, biomechanical studies done with CAD techniques and finite element methods (FEM) have been performed to design hand prosthesis. Gretsches et al. [8] developed a low-cost prosthetic



hand with ten degrees of freedom. The prosthesis was printed in acrylonitrile butadiene styrene (ABS) on a desktop 3D printer and designed with computer-aided design (CAD) software. During the design, special emphasis was set on the independent movement of the thumb. After testing on a patient, the prosthesis exhibited the facility to grasp objects, lightness, and scalability. However, factors such as grip strength and durability had low performance. On the other hand, Jones et al. [9] designed a 3D printed prosthetic hand named Touch Hand II. The research focused on improving the grip strength, mass, power usage, aesthetics, structural integrity, and cost of the prosthesis. Additionally, an overview of the control system for future research is presented. When the presented design was compared with seven low-cost commercial hand prostheses, it exhibited a similar performance. Van der Riet et. al [10] presented a low-cost design of a 3D printing multi-fingered prosthetic hand. The mechanical design included individually actuated fingers and 180° rotation of the wrist. The performance of the model was calculated in terms of grip strength and grip adaptability. The cylindrical grip strength of 250 g and the versatility to adapt to diverse objects were observed. Sayuk [11] designed and implemented a low-cost prosthetic hand intended for an 8-year old child. The analysis of the prosthetic hand was carried out by finite element simulations. Design novelties such as thumb's position, use of silicone material on the fingers, and rigid support with a compliance layer on the palm were obtained. Cuellar et al. [12] developed a low-cost hand prosthesis that consists of four degrees of freedom (DoF). The prosthesis was developed by FDM using polylactic acid (PLA). It is important to emphasise that the mobility is defined only for four fingers, leaving the thumb fixed. However, this allows various types of grip. Bustamante et al [13] developed a hand prosthesis that used 3D scanning of various hands to find the most appropriate design. As a result, it was possible to find an appropriate anthropomorphic design based on the physical characteristics of different types of people. The prosthesis consists of wires that were used as flexors and extenders. The mobility of the prosthesis is external and is carried out by the movement of the wrist.

Nowadays the use of structural optimisation by FEM analysis has become relevant to further improvement of the prosthetic hand design [14]. Alkhatib et al [15] developed a low-cost hand prosthesis by experimental and finite element methods. Two materials, acrylonitrile butadiene styrene (ABS) and polylactic acid (PLA) were used. Finally, as mentioned above, several efforts have been carried out to improve the design of upper limb prosthesis. However, for the specific case of hand prosthesis, few studies have focused on the mechanical design by finite element methods. The few existing studies are mostly centred on the control and automation of the prosthesis.

The main contribution of this paper is the design of a practical, robust, and low-cost prosthetic hand using finite element software. In order to obtain a large mechanical performance/cost ratio, a fused deposition modelling (FDM) with acrylonitrile butadiene styrene (ABS) is considered during the manufacturing process. Moreover, steel is proposed as rigid material for the pin connections.

### *1.1. Fundamentals of hand biomechanics*

The human hand is an important part of the human body which has evolved through time to enhance manipulative skills. The anatomy of the hand is formed by wrist (carpus), palm (metacarpus), and fingers (digiti manus) [16]. The human hand has a total of 27 bones: 8 carpals, 5 metacarpals, and 14 phalanges [4] as illustrated in Figure 1a. Additionally, the hand is conferred with twenty degrees of freedom (DOF) which represents the interaction of bones, joints, tendons, and muscles. In Figure 1b the different types of movements can be seen: Carpometacarpal (CMC), Trapeziometacarpal (TMC), Metacarpophalangeal (MCP), and Interphalangeal (IP). The figure shows the axes of rotation, as well as the type of movement, flexion or extension (f/e), and abduction or adduction (ab/ad). Movements such as flexion, extension, and abduction/adduction can be executed depending on the particular joint. Further details about the range of motion of each degree of freedom are specified by Chen Chen et al. and Cobos et al. [17,18].

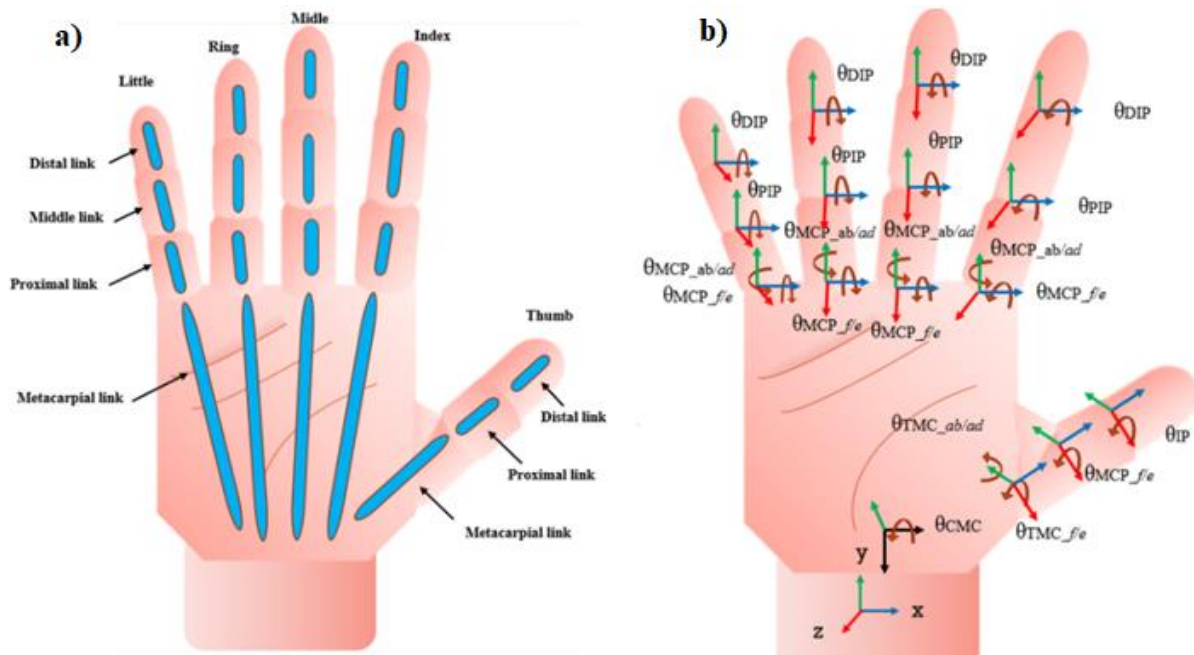

**Figure 1.** Human hand: (a) Skeleton; (b) Kinematic model.

## 2. Materials and Methods

### 2.1. Design Process

In order to obtain a practical, robust, and low-cost prosthetic hand, the conception and design of the prosthesis are determined primarily by the hand biomechanics followed by the technical and functional requirements defined in Table 1. The main objective of the design box (Table 1) is to assess the importance of several parameters (i.e. mechanical resistance, aesthetics, among others) on the design of the prosthetic hand. For this purpose, the relation between technical and functional requirements was measured by three different levels of influence namely high, medium, and low. The three variables with the highest influence both in the vertical and horizontal directions were determined and highlighted.

From Table 1, the mechanical design of the prosthetic hand is determined by its mechanical resistance, assembly, and manufacturability. During the design of the hand, special emphasis was set on material type, flexural/tensile strength, and costs associated with the manufacturing process. Once the design requirements were established and a review of the state of the art of prosthesis was performed, it was determined that the FDM technique is of paramount importance due to many advantages such as the printing of complex parts quickly and at a low cost compared to conventional methods. For this reason, FDM (3D printing) is proposed as the manufacturing technique for our prosthetic hand.

The selection of the thermoplastic material was determined according to the methodology presented in Figure 2. Ten characteristics placed on the edges of the polygon were evaluated by quantitative and qualitative analysis. The qualitative performance was evaluated by five levels, which range from 1 to 5, where 1 means poor and 5 excellent performance. The materials acrylonitrile butadiene styrene (ABS), polylactic acid (PLA), and ULTEM-9085 were evaluated. These materials were chosen by their market availability, mechanical properties, cost, and durability. After their assessment, material ULTEM-9085 showed relevant properties due to its high mechanical and chemical performance however, it also has the highest cost, which implies an increase in the production cost of the prosthesis. Thus, its feasibility is compromised. On the other hand, PLA exhibits an acceptable mechanical resistance at the lowest cost. However, it presents some

disadvantages such as low resistance to humidity and environmental conditions, which implies a reduction in the useful life of the prosthesis. Lastly, ABS presents a reasonable mechanical and chemical performance besides low cost and ready availability, both desirable characteristics during the manufacturing process of a prosthesis. Thus, this last material will be used in the following sections of the current article.

**Table 1.** Design box for hand prosthesis including functional and technical requirements.

		Material							Geometry			
		Shear strength	Flexural strength	Tensile strength	Density	Resistance environment	Resistance to temperature	Availability	Simplicity	Manufacturability	Scalability	Customisable
<b>Low</b>	Δ											
	§											
<b>High</b>	§											
<b>Medium</b>	□											
<b>Functional requirements</b>	<b>Technical requirements</b>											
<b>Mechanical resistance</b>	Flexion resistance	¥	§	§							§	
	Tension resistance	¥	§	§							¥	
	Torsional resistance	§	Δ	Δ							Δ	
	Impact resistance	¥	§	§								
<b>Assembly</b>	Easy assembly								§	§	§	
	Compactness		§	§					§	Δ		
<b>Durability</b>	Resist. to humidity					§		§				
	Resist. to corrosion					§		§				
<b>Manufacturing</b>	Low cost	Δ	Δ	Δ				§	§	§	§	
	Rapid manufacturing						Δ	§	Δ	§		¥
<b>Aesthetics</b>	Natural appearance								Δ	§	§	§
<b>Functionality</b>	Practical motricity	Δ	§	Δ					§	§		

*2.2. Proposed mechanical design of prosthetic hand*

In this section, we present a robust low-cost prosthetic hand considering the hand biomechanics described in section 1.1 and the design requirements obtained in section 2.1. The prosthesis’s design consists of 16 components that confer 14-degrees-of-freedom (DOF) to the hand. Flexion occurs in a range from 0° to 90° for the fingers as well as their proximal, medial, and distal components allowing the grasp of large and small objects making possible some of the characteristics of fine motricity of the hand. Constraints on the range of motion of the proposed hand prosthesis are presented in Table 2. From this besides the box design shown in Table 1, the current prosthetic hand has 14 DOF, which conferred the capacity to reproduce grips associated with security, and stability. In this way, the wrap-around grip for holding cylindrical objects and the side pinch-grip for objects smaller than the palm are reproduced. Additionally, the pinch-grip combined with other fingers provides enhanced dexterity and sensibility [4,6].

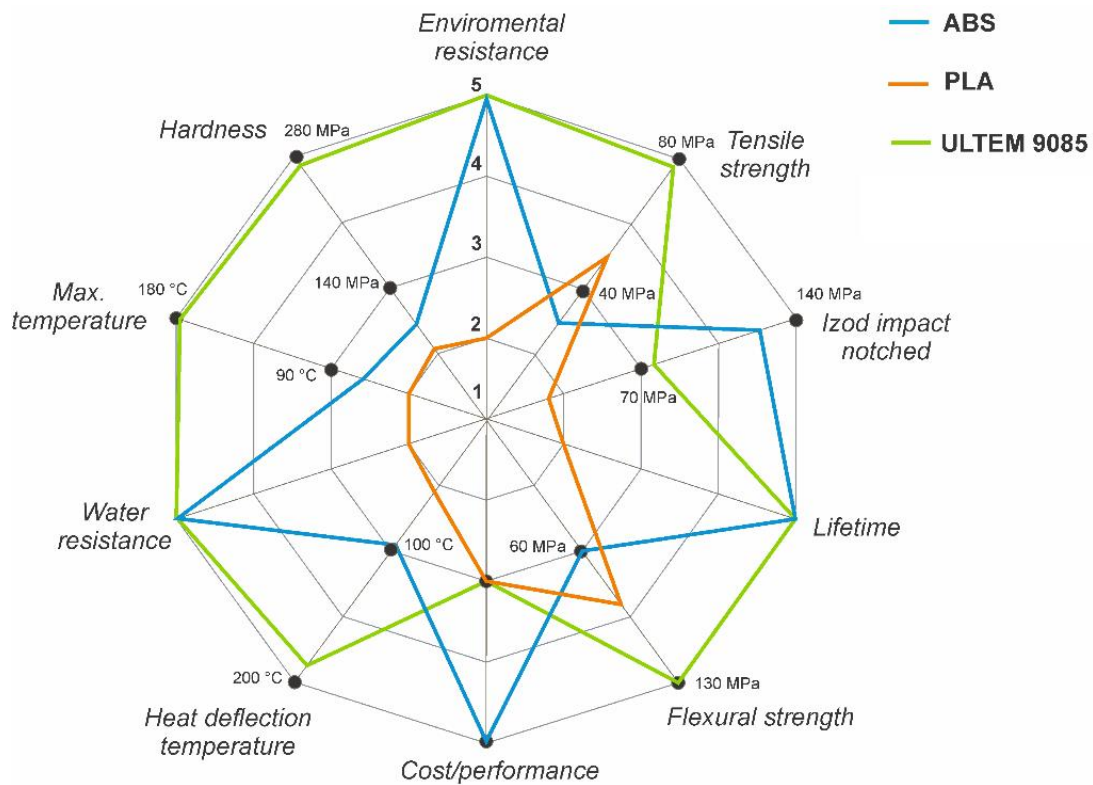

Figure 2. Material selection methodology.

Table 2. Constraints of range motion for different elements of the hand prosthesis.

N/P	Finger	Flexion	N/P	Finger	Flexion
1	<b>Thumb</b>			Proximal interphalangeal	0°-90°
	Trapeziometacarpal (TMC)	N/A		Distal interphalangeal/DIP	0°-90°
	Metacarpophalangeal (MCP)	0°-90°	3-5	<b>Middle, ring, little</b>	
2	Interphalangeal (IP)	0°-90°		CMC	N/A
	<b>Index</b>			MCP	0°-90°
	Carpometacarpal (CMC)	N/A		PIP	0°-90°
	MCP	0°-90°		DIP	0°-90°

The main components of the prosthesis are the palm, five proximal phalanges, four middle phalanges, five distal phalanges, and the forearm where the missing limb is positioned (see Figure 3 and Table 3). Assembly of the components is carried out by a set of pins located between each of the joints. Despite the current article is focused on the mechanical design and does not contemplate automatization, each component was designed to interact with wires, ligatures, and actuators that will enable the opening and closing of the fingers.

### 2.3. Finite element discrete model

Once the mechanical design of the prosthetic hand was obtained, its evaluation was carried out by FEM. For this purpose, several discrete models were developed using Abaqus FEM software. The numerical models evaluate the mechanical response of the prosthetic hand when subjected to tensile, flexural, and torsional loads. These kinds of loads can approximate the response of prosthesis on real conditions since are the most common on prosthesis components [9]. For the simulations, the loads were amplified for robustness since fewer demanding conditions are generated during common grips. Besides the rigid body pins, all components were modelled with C3D8R elements and conferred with the elastoplastic

properties of ABS. Accordingly, a Young modulus of 1937 MPa, Poisson’s ratio equal to 0.38, yield strength of 15 MPa, and density of 1024 kg/m<sup>3</sup> were applied to the model in concordance with Dundar and Păcurar et al. [19,20]. Boundary conditions (BCs) are different for each load case. However, considering a load case (i.e. tension), the same BCs are applied on each finger comprised of distal, medial, and proximal phalanges. Figure 4 shows the BCs for each load case, with each case shown on a different finger for illustration purposes. On the other hand, boundary conditions of the wrist remain the same in all simulations. Yellow, purple, and green arrows reflect tensile, flexural, and torsional loads applied, respectively. Lastly, the interaction of all components was guaranteed by a general contact condition with a friction coefficient of 0.01. An average mesh size of 2 mm was used in the simulations. The 0.1 MPa was chosen since guarantee a typical load condition on hand prosthesis as it is shown by Jones et al. [9].

**Table 3.** Components of the hand prosthesis.

Item No	Name	Item No	Name
1	Palm	9	Middle link (index and ring)
2	Distal link (thumb, index, middle, and ring)	10	Palm connecting pin (1)
3	Proximal link (thumb, index, and ring)	11	Pin cap (13)
4	Middle link (little)	12	Finger connecting pin (10)
5	Proximal link (little)	13	Upper palm cover
6	Distal link (little)	14	Lower palm cover
7	Middle link (middle)	15	Forearm
8	Proximal link (middle)	16	Wrist connecting pin (2)

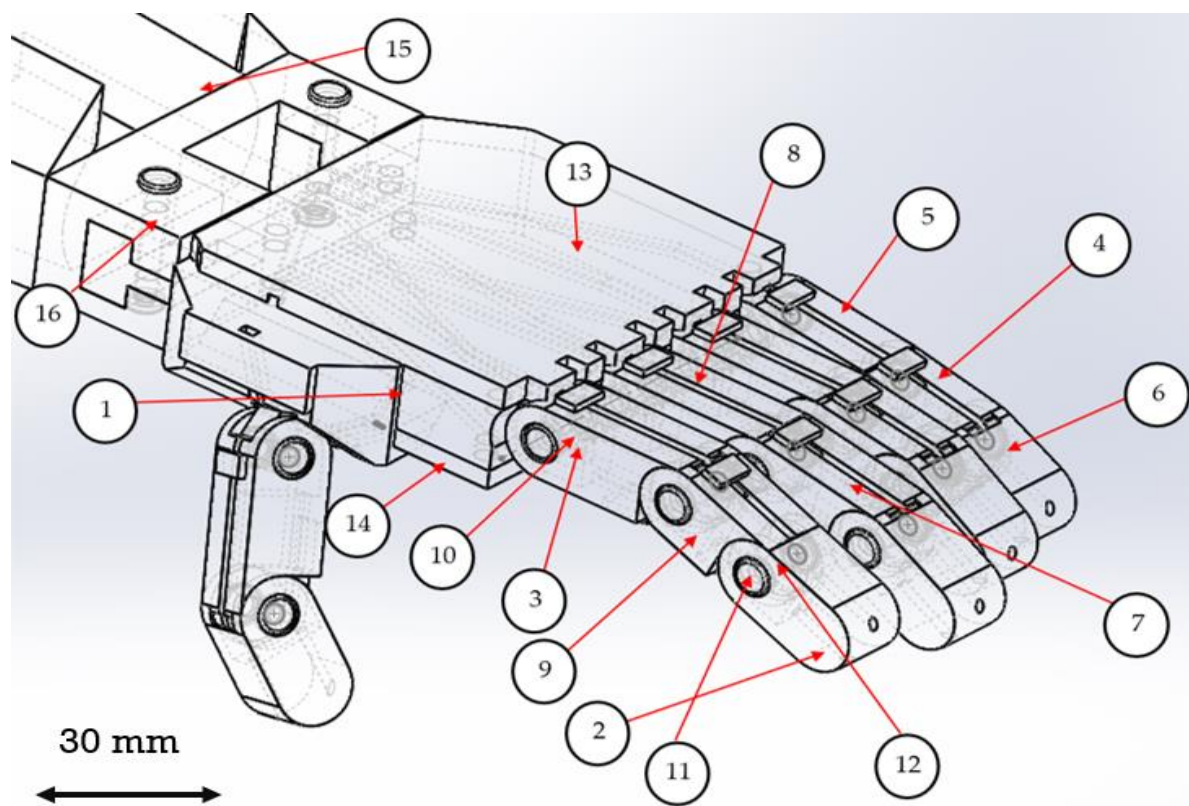

**Figure 3.** Design of the hand prosthesis. Each number is shown in Table 3.

### 3. Results and discussion

#### 3.1. Mechanical response of the prosthetic hand under tensile load

The stress state distribution of the prosthesis when it is subjected to a tensile load of 0.1 MPa is presented in Figure 5. This load was placed on the back of each distal to achieve a pulling effect as can be seen in Figure 4. As expected, the stress generated is caused by contact between the pins and the bearing surfaces of the palm, distal, proximal, and medial components. However, the highest Von Mises stress value of 10 MPa is reached at the bearing surface of the joint region between the proximal and palm components. Similar behaviour is seen at the join of the palm and the thumb. Finally, minimum stresses are observed on the body of the palm, which is consistent since the palm involves a greater area to be loaded.

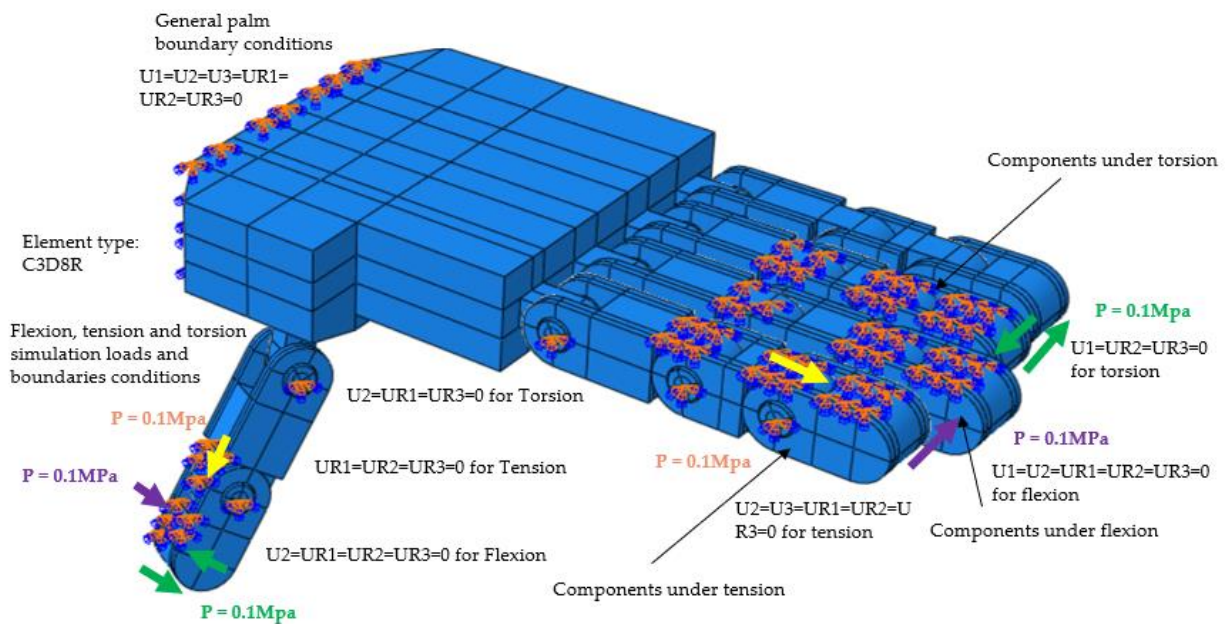

Figure 4. Discrete model of the human hand prosthesis and boundary conditions.

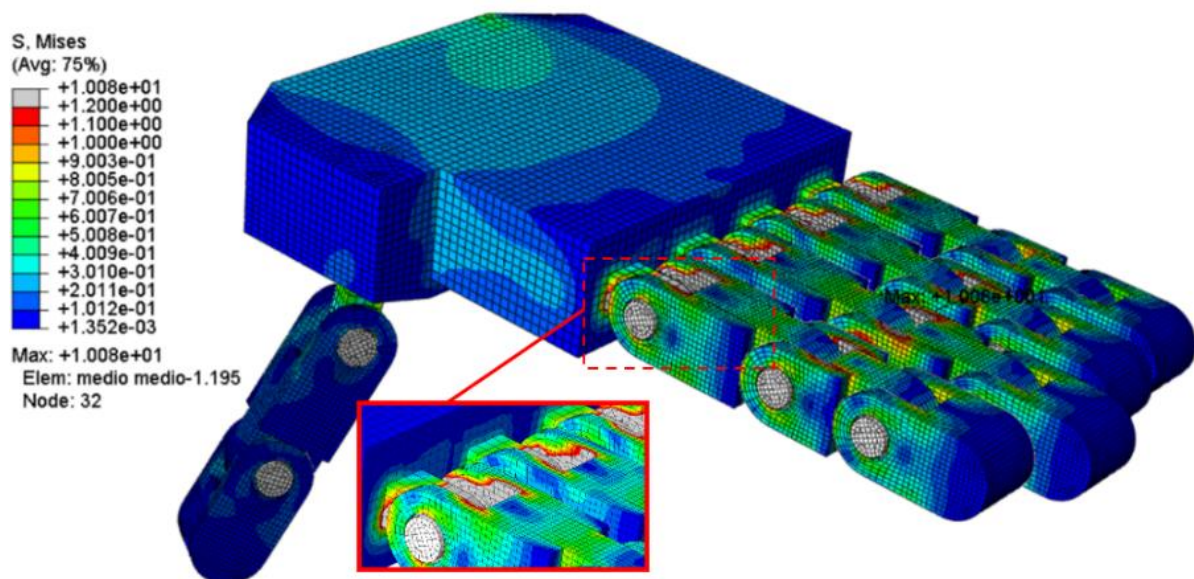
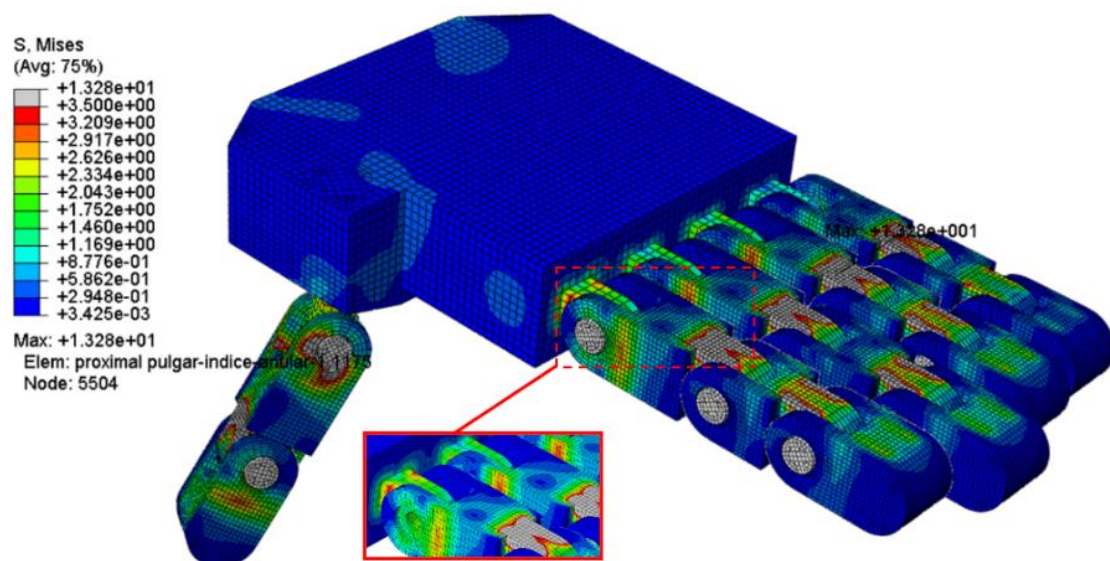

Figure 5. Von Mises stress state of the prosthetic hand under tensile loads, units in MPa.



### 3.2. Mechanical response of the prosthetic hand under flexural loads

As seen in Figure 6, the stress on the prosthesis is distributed when a load of 0.1 MPa is applied to each distal phalange. In this case, the load was placed on the side of each distal, to obtain a bending effect as can be seen in Figure 4. From this, a stress state of the order of 13 MPa is computed. Even though the left part of the proximal unions showed high stresses, the central part of the proximal and medial components is subjected to even higher stresses due to their dimensions. In those regions, the maximum stress of 13 MPa was calculated. The stress generated is caused by the force momentums acting between the pins and the support surfaces of the palm, distal, proximal, and medial components. These regions are the most compromised during the bending process. Similar behaviour is also present in the thumb, but due to its shorter length, the stress on it is lower. Lastly, minimum stresses were also observed on the palm's body as in the previous loading case.

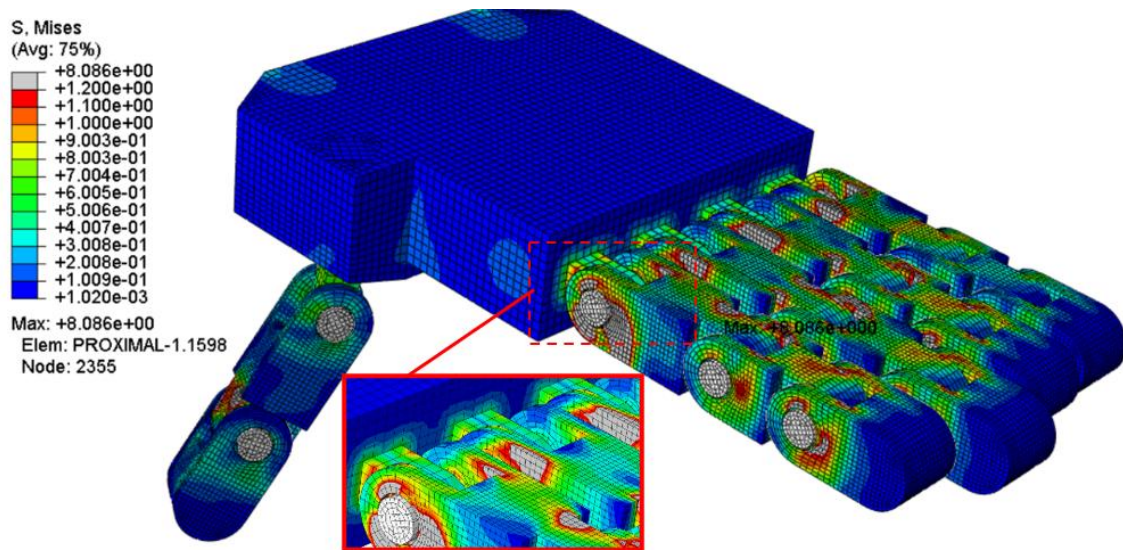

**Figure 6.** Von Mises stress state of the prosthetic hand under flexural loads, units in MPa.

### 3.3. Mechanical response of the prosthetic hand under torsional loads

For the torsional case, the 0.1 MPa loads were located on the surfaces forming a half-circle in the distal area, one 0.1 MPa load on each side. In this way, they act in opposite directions on the axis of rotation to produce the torsion of the components. Figure 7 shows the stress distribution due to these loads. As expected, the pin unions at the proximal, medial, and distal parts are also the most compromised during the loading process. The maximum stress of 8 MPa was computed, which represents the lowest value of stress recorded in all loading cases considered. The minimum stresses were observed in the palm's body, becoming increasingly large near the joints with the fingers.

Lastly, concluded the study, the stress distribution on a prosthetic hand was obtained and compared. In this way, the highest stress values for tensile (10.08 MPa), flexural (13.28 MPa), and torsional (8.08 MPa) conditions were calculated. However, in all cases, the stress values were lower than the yield stress of 15 MPa for acrylonitrile butadiene styrene/ABS. Thus, all components are within permissible limits of stress. Additionally, the numerical results showed that the thickness (3 mm) of the distal, proximal, and medial components together with the diameter of the pinhole (4 mm) allowed an adequate distribution of any kind of stress. Finally, the permissible loads calculated considering the area highest stressed, reveals a higher performance of the current prosthesis. In this way, a higher load is required to get the failure state according to [22-23].



**Figure 7.** Von Mises stress state of the prosthetic hand under torsional loads, units in MPa.

#### 4. Conclusions

In the current work, the mechanical analysis of a practical and low-cost prosthetic hand by the finite element method was obtained. During the study, special emphasis was set on the design process including functional and technical requirements, correct material selection, and numerical techniques to reproduce the intended DOF. Thus, from this study we conclude:

1. The main functional characteristics of our prosthesis are: practicality since the prosthesis has 14 DOF which confers the ability to grasp objects in different manners; Strength since the ABS thermoplastic material provides an acceptable mechanical resistance (15 MPa)
2. Even though there are multiple thermoplastic materials used in FDM, one of the most advantageous is ABS (see Figure 2) which presents many desirable properties such as low cost, availability, and mechanical resistance, all important when the prosthetic hand is designed.
3. As a result, a practical and objective design methodology focused on the prosthetic hand design is presented. From this methodology, the correct identification of design variables and adequate material selection is presented (section 2.1).
4. Using a load value of 0.1 MPa applied in all discrete models, different stress distribution and maximum stress were computed for each loading condition. The highest maximum stress (13.28 MPa) was obtained when the prosthesis was subjected to a flexural load. On the other hand, the smallest maximum stress close to 8 MPa was computed when torsional loads were considered. From this result, the importance of a robust mechanical response to bending becomes essential, especially when the grasp of heavy objects is required. Besides, the results showed that in the case of grasping objects the integrity of the prosthesis will be maintained.
5. Finally the importance of FE discrete models on the design of a prosthetic hand was observed. FE models show the most compromised components of the hand prosthesis when they are subjected to the three different kinds of stresses. In this way, the feasibility of our numerical techniques including material properties and contact interactions were verified by similar techniques found in the literature [14, 22, 23].

#### Acknowledgments

The authors gratefully acknowledge the support from the Consejo Nacional de Ciencia y Tecnología (CONACYT) of the Mexican Government.

## References

- [1] Plott J, Chen R, Wensman J, Shih A and Jin Y A 2015 Additive manufacturing of custom orthoses and prostheses - A review. *Procedia CIRP*, **36**, 199–204.
- [2] Alvial P, Bravo G, Bustos M P, Moreno G, Alfaro R, Cancino R and Zagal J C 2018 Quantitative functional evaluation of a 3D–printed silicone-embedded prosthesis for partial hand amputation: A case report. *Journal of Hand Therapy*, **31(1)**, 129-136.
- [3] Cipriani C, Controzzi M, and Carrozza M C, Objectives, 2010 Objectives, criteria and methods for the design of the SmartHand transradial prosthesis. *Robotica*, **28(6)**, 919-27.
- [4] Gama E N, Aviles O F, and Amaya D 2014 Anthropomorphic robotic hands: a review. *Ingeniería y Desarrollo*, **32(2)**, 279-313.
- [5] Fourie R, and Stopforth R 2017 The mechanical design of a biologically inspired prosthetic hand, the touch hand 3. In *2017 Pattern Recognition Association of South Africa and Robotics and Mechatronics (PRASA-RobMech)*, 38-43.
- [6] Laliberté T, Baril M, Guay F, and Gosselin C 2010 Towards the design of a prosthetic underactuated hand. *Mechanical Sciences*, **1(1)**, 19-26.
- [7] Clement R G E, Bugler K E and Oliver C W 2011 Bionic prosthetic hands: A review of present technology and future aspirations. *The surgeon*, **9(6)**, 336-40.
- [8] Gretsch K F, Lather H D, Peddada K V, Deeken C R, Wall L B and Goldfarb C A 2016 Development of novel 3D-printed robotic prosthetic for transradial amputees. *Prosthetics and Orthotics International*, **40(3)**, 400–03.
- [9] Jones G, and Stopforth R 2016 Mechanical design and development of the touch hand ii prosthetic hand. *R& D JS Afr. Inst. Mech. Eng*, **32**, 23-34.
- [10] van der Riet D, Stopforth R, Bright G, and Diegel O 2015 The low cost design of a 3D printed multi-fingered myoelectric prosthetic hand. In *Mechatronics: Principles, Technologies and Applications*, Nova Science Publishers, Inc., 85-117.
- [11] Sayuk A 2015 Design and implementation of a low cost hand for prosthetic applications. Doctoral dissertation, Master's Thesis, University of Coimbra, Coimbra, Spain.
- [12] Cuellar J S, Smit G, Breedveld P, Zadpoor A A and Plettenburg D 2019 Functional evaluation of a non-assembly 3D-printed hand prosthesis. *Proceedings of the Institution of Mechanical Engineers, Part H: Journal of Engineering in Medicine*, **233(11)**, 1122-31.
- [13] Bustamante M, Vega-Centeno R, Sánchez M and Mio R 2018 A Parametric 3D-Printed Body Powered Hand Prosthesis Based on the Four-Bar Linkage Mechanism. In *2018 IEEE 18<sup>th</sup> International Conference on Bioinformatics and Bioengineering (BIBE)*, 79-85.
- [14] Annanto G P, Ismail R, Haryanto I, Ariyanto M, Pambudi K A and Pranoto K A 2019 Numerical analysis of stress and displacement on the index finger of the prosthetic hand due to hook position. In *AIP Conference Proceedings*, AIP Publishing LLC, (Vol. 2114, No.1, p. 050017).
- [15] Alkhatib F, Cabibihan J J and Mahdi E 2019 Data for benchmarking low-cost, 3D printed prosthetic hands. *Data in brief*, **25**, 104163.
- [16] Jaworski Ł and Karpiński R 2017 Biomechanics of the human hand. *Journal of Technology and Exploitation in Mechanical Engineering*, **3(1)**, 28-33.
- [17] Chen Chen F, Appendino S, Battezzato A, Favetto A, Mousavi M and Pescarmona F 2013 Constraint study for a hand exoskeleton: human hand kinematics and dynamics. *Journal of Robotics*.
- [18] Cobos S, Ferre M, Uran M S, Ortego J and Pena C 2008 Efficient human hand kinematics for manipulation tasks. In *2008 IEEE/RSJ International Conference on Intelligent Robots and Systems*, 2246-51.
- [19] Dundar M A 2017 Strain Rate Dependence And Impact Behavior Of Abs (acrylonitrile Butadiene-Styrene) Amorphous Thermoplastic. Doctor of Philosophy, Wayne State University, Detroit, Michigan.

- [20] Păcurar R, Păcurar A, Popișter F and Popișter A 2015 Finite Element Analysis to Improve the Accuracy of ABS Plastic Parts Made by Desktop 3D Printing Method. *Applied Mechanics and Materials*, **760**, 509-14.
- [21] Hichert M, Vardy A N, and Plettenburg D 2018 Fatigue-free operation of most body-powered prostheses not feasible for majority of users with trans-radial deficiency. *Prosthetics and orthotics international*, **42(1)**, 84-92.
- [22] Biddis E A, Bogoch E R and Meguid S A 2004 Three-dimensional finite element analysis of prosthetic finger joint implants. *International Journal of Mechanics and Materials in Design*, **1(4)**, 317-328.
- [23] Amornvit P, Rokaya D, Keawcharoen K and Thongpulsawasdi N 2013 Stress distribution in implant retained finger prosthesis: a finite element study. *Journal of clinical and diagnostic research: JCDR*, **7(12)**, 2851-54.